

## **Rapid Tooling for Plastic Injection Moulding Using Indirect Rapid Tooling Processes**

**F. Jorge Lino, Pedro V. Vasconcelos, Ricardo Paiva and Rui J. Neto**  
INEGI, Instituto de Engenharia Mecânica e Gestão Industrial, Rua do Barroco,  
174, 4465-591 Leça do Balio, Portugal, Tel.: (351) 229578710, Fax: (351)  
229537352, [falves@inegi.up.pt](mailto:falves@inegi.up.pt), [www.fe.up.pt/~falves](http://www.fe.up.pt/~falves)

### **Abstract:**

Rapid Prototyping (RP) and Rapid Tooling (RT) are well known processes for rapidly develop new products and consequently reduce the time to market. In Portugal, many companies are still not exploring the full advantages of using these technologies for new products development and produce reduced runs. This work presents some results obtained with composite tools manufactured for thermoplastics injection. These tools are obtained by casting a aluminium filled resin or by arc spray metal tooling over Rapid Prototyping models. Different properties, such as: moulds roughness, hardness and the wear were determined and compared, and the suitability of these processes are evaluated to rapidly produce prototype moulds to inject thermoplastic models and pre series.

### **Introduction:**

RP and RT systems are used to reduce product development time, schedules and deadlines. This way the companies are able to deliver new products in less time, with greater quality at lower expenses. Two categories of RT exist; a direct approach, where the RP machine builds the actual tooling inserts (examples of these processes are the DMLS, SLSm, ProMetal, LENS, etc.), and an indirect category, where a RP master pattern is used to produce a mould.

Currently, there is an increase interest in RT solutions. Whether the application is prototype, bridge, or short-run production, RT represents an excellent opportunity to reduce both time and expense. Methods of RT are relatively new, and some are still in development all around the world.

The production of prototypes moulds in silicone, polyurethane and epoxy resins, allow the production of dozens to hundreds parts for visual aids, geometric and dimensional analysis, and frequently thermoplastic functional prototypes or pre series. Particularly, for these last functional prototypes, epoxy based composites can be used to manufacture the injection moulds for thermoplastics. These types of moulds can withstand the high pressures and

temperatures of the thermoplastic injection cycle. Naturally, their expected life lies between 100 and 1000 cycles which are significantly lower than the ones obtained with the conventional metallic moulds that are more expensive and time consuming and require intensive machining operations. Considering that the development of an industrial product rarely demands a higher number of prototypes, it can be concluded that these technologies are very attractive and well adjusted for rapid development of new products, reducing the time to market and increasing the companies' competitiveness [1-5].

Fig. 1 shows one epoxy based composite mould that was used in the production of a thermoplastic part included in functional prototypes of a terminal of an automatic teller machine. Fig. 2 presents other composite mould and a pre series of a latch.

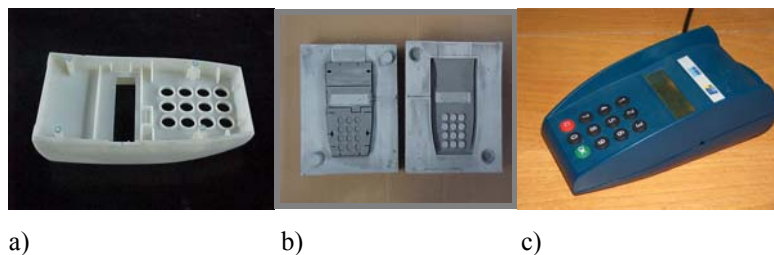

Fig. 1 - New products development using composite moulds: a) ABS prototype model obtained by High Speed Machining (HSM) and used as a master to produce the composite mould; b) composite mould in aluminium filled resin; c) final component with the thermoplastic injected part.

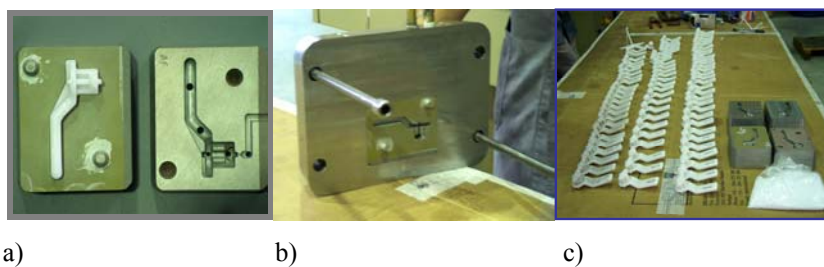

Fig. 2 - Epoxy based composite mould for thermoplastic injection of a latch: a) composite mould; b) preparation of the core and cavity in the standard plate of an industrial injection machine; c) pre series of the latch.

The composite moulds based on high temperature epoxy resins, used in rapid tooling, exhibit an intermediate durability between the soft and the hard tooling [2-4]. This is due to the combination of the high strength and good thermal stability of the epoxy resin, with the stiffness, hardness and good thermal conductivity of the metallic particles. This last characteristic reduces the thermal shock in the mould in each injection cycle, lowering the mould temperature and the injection cycle time.

Although this technology seems to be considered for pre series production of thermoplastic parts, difficulties related with the brittleness, size, erosion and the reduced thermal conductivity of the mould, limits their more popular use. Considering this limitation, our research group has been working in a complementary solution using sprayed-metal prototype moulds. These moulds are obtained by depositing an outside layer of a zinc-based alloy (kirksite type) over RP models, followed by a casting of a low cost backup of aluminium filled polyurethane resin (epoxy or acrylic resins can also be used). This low cost resin (cheaper than the high temperature epoxy resin used in the composite moulds) makes this process very attractive to produce large parts. It is expected to achieve with these moulds a slight improvement in the heat dissipation capacity (lower cooling cycles), better mechanical resistance and accuracy (the mould-making process introduces little or no additional shrink).

The implementation of the two indirect rapid tooling processes to manufacture prototype moulds for production of functional prototypes and pre series, with reduced costs and reduced time-to-market, will allow Portuguese companies, that have a larger tradition in manufacturing moulds for thermoplastic injection industry, to increase their competitiveness in a continuous more demanding international market [5, 6-8].

## **Experimental:**

Two types of moulds were manufactured by indirect rapid tooling:

1. Composite moulds;
2. Sprayed-metal moulds.

### **Composite Moulds**

Aluminium filled composites, with different aluminium particles concentrations (AF), and hybrid composites composed by aluminium particles and milled fibres (AFV) were produced (see table 1). In previous work [9-11],

the authors studied different resin formulations and curing cycles and end-up with these two most promising compositions for this indirect rapid tooling application. The respective microstructures of the two types of composites are presented in fig. 3. The epoxy matrix system composition is indicated in table 2, and the technical characteristics of the dispersed materials presented in table 3.

Fig. 4 shows the main steps of the technique used to cast the composite resins [12]. This procedure assures composite moulds with low level of porosity.

Table 1 – Designation and composition (in volume %) of the materials produced.

Epoxy resin	Aluminium filled composite	Hybrid composite
<b>A</b> A – 100%	<b>AF</b> A – 59 % F – 41 %	<b>AGF</b> A – 57.5 % F – 38.5 %, G – 4 %
A – Epoxy resin; F – Aluminium particles; G – Glass milled fibres		

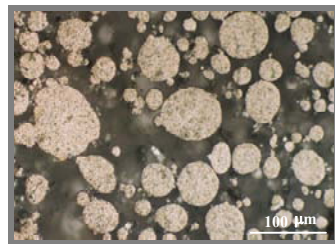

a)

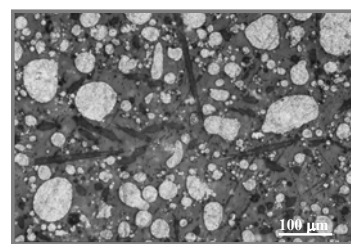

b)

Fig. 3 - Epoxy resin composites filled with: a) aluminium (grey round particles); b) aluminium and milled glass fibres (dark elongated filaments).

Table 2 - Epoxy system composition.

Epoxy system	Araldite LY5210/ Aradur HY2954 (Vantico-USA)
Epoxy components	<ul style="list-style-type: none"> <li>● TGDDM = N, N, N', N' - tetraglycidyl - 4, 4' - diaminodifenylmethane</li> <li>● butahedioldiglycidyl ether</li> </ul>
Curing agent	● 2, 2'-dimetil-4, 4'-metilenobis (ciclohexilamine)

Table 3 - Technical characteristics of the aluminium particles and milled fibres.

Fibre type	Manufacturer	Dimensions	Sizing
Aluminium particles (>99% Al)	Hexcel (France)	P200 degree	-
Glass fibres	PPG (USA)	215/11 $\mu$ m (l/d)*	Polyvinyl acetate with silane
Carbon fibres	Toray (Japan)	63/7 $\mu$ m (l/d)*	1 wt% epoxy

\*l/d – fibre length/diameter.

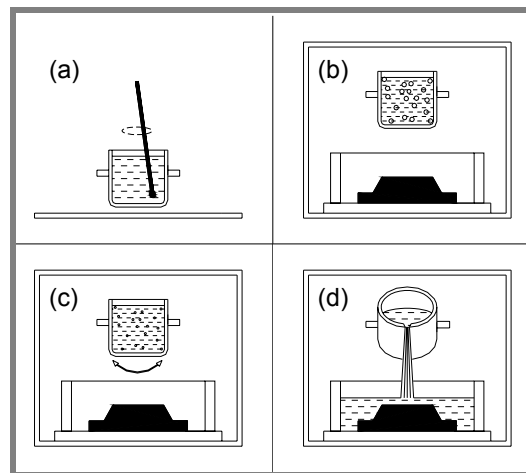

Fig.4 - Processing method using vacuum pouring: a) manual component mixture; b) first degassing; c) second degassing with agitation; d) vacuum pouring.

The processing conditions, dimensional changes occurring during the process, mechanical and wear resistance with the temperature, and the thermal conductivity, were studied with detail, aiming to produce moulds with optimised properties for thermoplastic injection.

After tested and characterized in laboratory, the two composite moulds (cost of the mixture is 13.5/kg) were applied in an industrial thermoplastic injection machine for tests.

#### **Sprayed-Metal Moulds**

After the CAD design of the part to be manufactured, the STL file was sent to a Rapid Prototyping machine (stereolithography VIPERsi2, 3D Systems, USA),

and the SL model produced. It should be mentioned that although a SL model was used for this part, other types of RP models, such as LOM (paper models) could be employed, due to the fact that during an adequate metallic projection, the maximum temperature reached by the shell is lower than 50°C [6].

The RP model was placed in a support structure that defines the parting surface, mounted in wood box and manually coated (using a brush) with a thin layer of a release agent fluid (polyvinyl alcohol - PVA, MCP HEK Tooling, Germany) (fig. 5a). It should be mentioned that the support structure can be modelled using CAD 3D systems, and also manufactured using RP technologies.

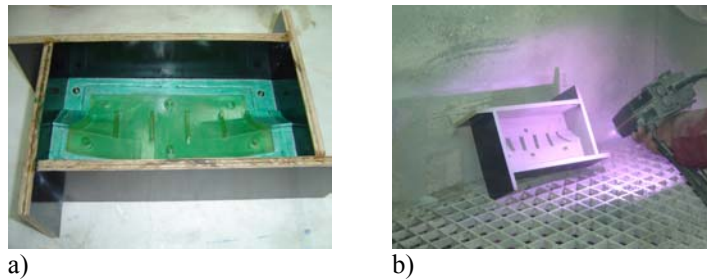

Fig. 5 - Arc spray metal tooling: a) wood box containing the stereolithography RP model coated with the release agent; b) deposition of the metallic coating.

The half mould was then sprayed (fig. 5b) with a MCP/TAFA Arc Spray Unit (composed by a Arc spray gun 8830, a arc spray unit 30x8A 200A power unit and a 47x51 control console, MCP HEK tooling, Germany), with the following parameters:

1. Voltage: 22V (produces a current of 180A)
2. Spray pressure: 3.5 bar
3. Wire feed pressure: 4.2 bar
4. Wire material: MCP mould making 204M (MCP 400) of 1,6mm (this wire material resembles a Kirksite alloy and is made exclusively for TAFA's cold spray mould making process to create metal faced tooling).

Initially, a stand-off distance of about 400-500mm and a wide sweeping motion of the spray gun were used. Considering that the SL model is very sensitive to the temperature, the deposition was controlled with several interruptions, for cooling. After a thin coating was obtained in all surfaces, the projection parameters were changed (to 27V and a lower stand-off distance) to increase the deposition rate. When a thickness of around 1-2mm was obtained

the process was concluded. Figure 6 shows the prototype after the shell deposition process.



Fig. 6 - Half mould after deposition of the metallic coating.

The metallic layer was backed-up by casting a aluminium filled polyurethane resin (F19, Axson, France; the aluminium powder properties are indicated in table 3), as shown in fig. 7. The weight ratio aluminium/resin selected was 2/1 (cost is around 10€/kg). The same preparation steps were repeated for the second half of the mould.

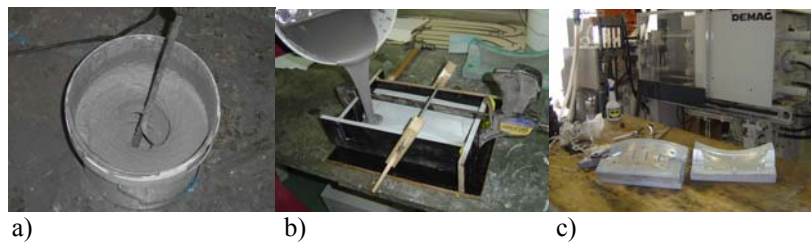
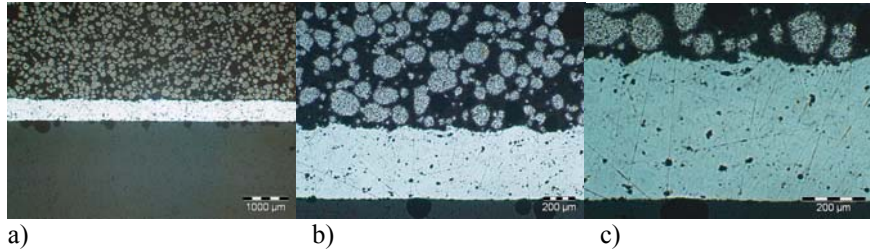

Fig. 7 - Back up of the first half mould: a) mixing of the resin with the catalyst and the aluminium metallic particles; b) casting the slurry over the metallic shell; c) final mould.

Fig. 8 is a cross section of one mould used to calibrate the right projection thickness; showing in the upper part the resin filled with round aluminium particles and in the bottom the metallic shell with a considerable amount of porosity (this is a normal amount of porosity for this process).



a) b) c)  
 Fig. 8 - Cross-section of one mould composed by a metallic layer and a back up in composite resin; a) cross section of the mould; b) detail of the two phases; c) detail of the metallic shell, showing small round black dots, corresponding to the shell porosity.

## Results:

### Composite moulds

Flexural tests in samples, with a rectangular section of 13x18mm<sup>2</sup> and a length of 200mm, show that the aluminium particles improve the flexural strength and the elastic modulus of the epoxy resin (see fig. 9). The incorporation of milled fibres contributes to a small increase of the flexural strength.

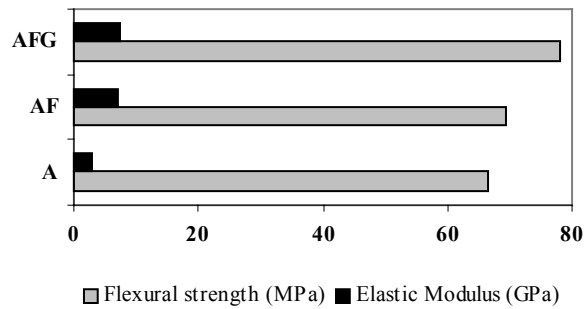

Fig. 9 - Flexural strength and elastic modulus of the A, AF and AFG materials.

Dynamic mechanical thermal analysis (DMTA) shows that metallic particles improve the material stiffness, at both, room temperature and high temperatures (200°C). At 200° C the elastic modulus is abruptly reduced due to the glass transition temperature (fig. 10), however, it should be pointed out that during the



thermoplastic injection cycle, the mould does not reaches this temperature.

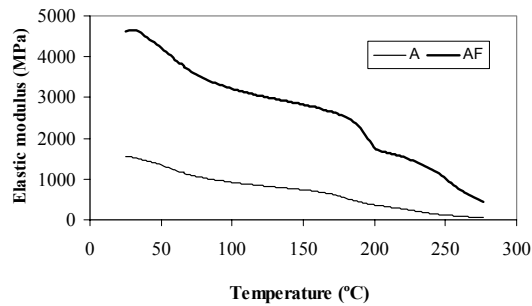

Fig. 10 - Elastic modulus as a function of temperature for the neat resin A and aluminium filled epoxy AF, obtained in DMTA tests.

The graph of fig. 10 does not show the AFG plot because it has a similar DMTA behaviour of the AF composites.

The high aluminium particles concentration allows a significant reduction in the coefficient of thermal expansion (CTE - Fig. 11), which is a very important factor for this type of applications (enhances the process accuracy).

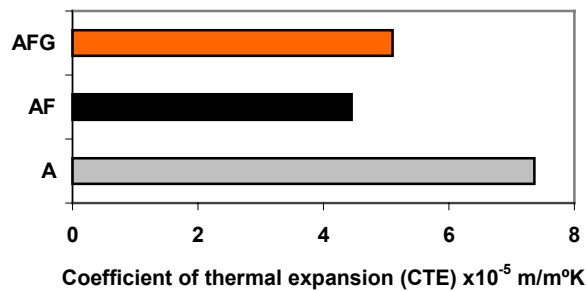

Fig. 11 - CTE of A epoxy resin and of the two composites; AF and AFG.

Aluminium particles increase the thermal conductivity of the composite, relatively to the epoxy matrix, about an order of magnitude. The milled glass fibres, although well mixed in the composite, ensuring a high concentration of

metallic particles in the composite, have a small effect on the thermal conductivity, as one can see in Fig. 12.

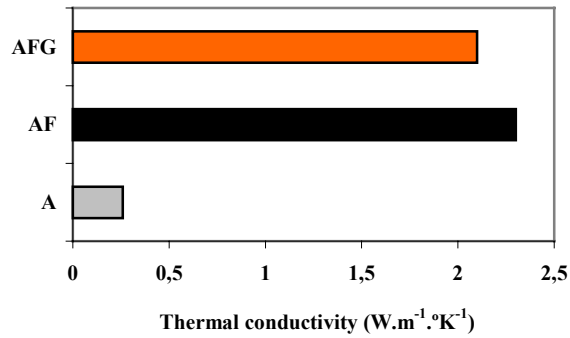

Fig. 12 - Thermal conductivity of the three tested materials (Kirksite alloy Z35541 – ASTM B86 [14] has 105.0 W.m<sup>-1</sup>.°K<sup>-1</sup>).

Fig. 13 shows the specific wear rate results of the A, AF and AFG materials, at room temperature and at 160°C (this temperature was selected because is in the range of the typical thermoplastic injection temperatures), determined in a reciprocating tribometer [13]. The AFG hybrid composite exhibits a significantly better wear behaviour than the conventional AF composite.

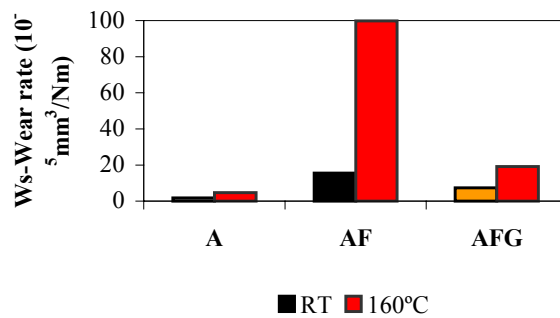

Fig. 13 - Specific wear rate of epoxy (A), epoxy with aluminium (AF) and epoxy with aluminium and fibres (AFG) systems, at room temperature and at 160°C, determined in the reciprocating tribometer.

The moulds wear was measured by an indirect approach, through the determination of the dimensional differences measured in thermoplastic injected parts (latch) in the same mould, spaced each other by 50 injection cycles. The six dimensions that were controlled in each part are indicated in Fig. 14. The results are presented in the Table 4.

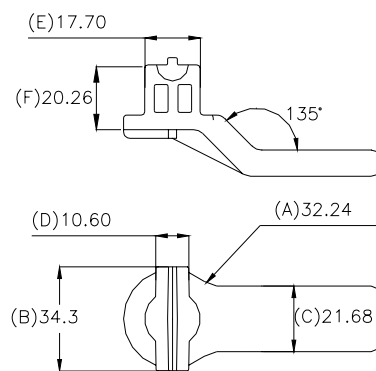

Fig. 14 - Latch model dimensions used in the geometric control.

Table 4 - Results of the dimensional control of the injected parts in the AF and AFG moulds, separated by 50 injection cycles.

Dimension	A	B	C	D	E	F
AF difference (mm)	0.02	0.10	0.03	0.03	0.05	0.03
AFG difference (mm)	0	0	0	0	0	0.01

After 50 injection cycles, the AF mould reveals some quantifiable wear, while in the AFG mould no significant wear was yet detected (accuracy: 0.01mm).

The mould surface finishing was also evaluated, after 90 injection cycles. The initial medium roughness (Ra) of both moulds was 0.85µm and, after 90 injections, was 1.41µm for the AF mould and only 0.94µm for the AFG mould (tab. 5). This result also confirms that the AFG composite mould exhibits better physical integrity and erosive wear resistance than the AF composite, which is in accordance with the laboratorial results.

Table 5 - Surface roughness of the studied moulds, after 90 injection cycles.

Mould	Roughness criteria, ( $\mu\text{m}$ )		
	Ra	Rz	Rmáx
<b>AF</b>	1.41	11.37	13.83
<b>AFG</b>	0.94	6.84	7.96

SEM images of the two composites moulds surfaces (Fig. 15) also reveal a deeper excoriation in the AF moulds, confirming the quantitative results.

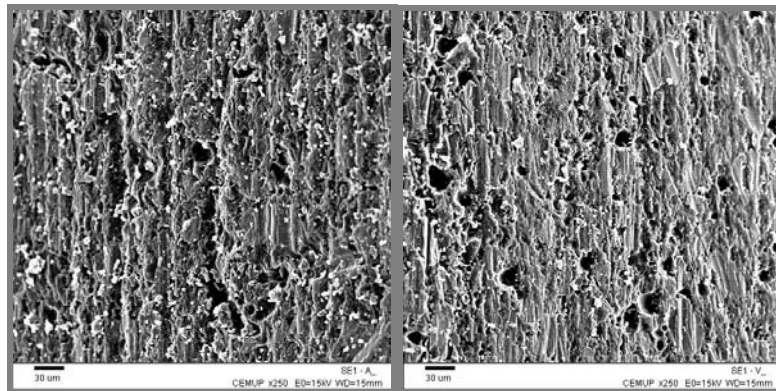

a)

b)

Fig. 15 - SEM images of the moulding cavity surfaces, revealing the degree of excoriation occurred in the thermoplastic flow direction of the: a) AF mould with more severe excoriation, deeper grooves, and; b) AFG moulds, with softer surfaces.

### Sprayed-Metal Moulds

The surface roughness of the model, the release coating and the mould was measured, and the values obtained are indicated in table 6. As one can see, there is a significant increase in the mould surface roughness derived from the manual application of the release agent over the SLA model.

The hardness of the shell and backup were determined and the respective values are indicated in table 7, and compared with the ones obtained in the composite moulds. These results show that there are no advantages in using the metallic layer to produce harder moulds surfaces, however, the expected better thermal and mechanical performance of these moulds (kirksite properties

indicated in reference [14]), associated to a lower cost raw materials (specially for large moulds), makes the metal sprayed moulds very attractive (this is also confirmed in references [5, 15])

Table 6 - Surface roughness of the model, coating and mould.

	<b>Roughness criteria, (<math>\mu\text{m}</math>)</b>		
	Ra	Rz	Rmáx
<b>SLA model</b>	0.74	4.6	6.43
<b>PVA coating</b>	2.73	17.98	22.93
<b>Metallic shell</b>	2.52	11.48	19.75

Table 7 – Hardness of the metal sprayed mould and composite moulds.

	<b>Vickers micro hardness (200gf)</b>
<b>Metallic shell</b>	40.2
<b>Resin</b>	12.7
<b>Composite moulds (AF and AFG)</b>	53 Barcol (39 Vickers)

The thermal and mechanical performance of the metal-sprayed moulds is currently under investigation.

### **Conclusions:**

Epoxy resin composites and sprayed-metal prototype moulds are well suited for rapid tooling applications, if adequate processing conditions are used. In this paper it was shown that the heat capacity dissipation of the composites is related with; amount of metallic Al particles allowed by the epoxy system; or the metal-sprayed shell.

For epoxy composite moulds, the high metallic concentrations (around 40% in vol., improves the thermal conductivity) reduce the injection cycles and the thermal shock and increase the mould life. The addition of the metallic particles also improves the elastic modulus at low and high temperature and reduces the CTE.

Milled glass fibres added in small concentrations (4 %) to the epoxy aluminium filled composite,s improve substantially the composite abrasive and

erosive wear resistance, and consequently, this type of composite is particularly indicated for rapid tooling applications.

Spray metal tooling is able to produce mould cavities with similar roughness and is a process candidate for parts of significant size and low-to-medium complexity.

The main disadvantages of both types of moulds are their limited life, and complex shapes may require adding metal inserts, increasing cost and production time.

### **Acknowledgements:**

Financial support from FEDER through the project POCTI/EME/41199/2001, “Development of an Indirect Rapid Tooling Process Based in Polymeric Matrix Composites”, approved by the Fundação para a Ciência e Tecnologia (FCT) and POCTI.

Financial support from FEDER and Ministério da Economia, through the project FRF – Rapid Tooling, Program PRIME, Medida 2.2B, approved by Agência de Inovação for the period 2002/2005.

### **References:**

1. P. Vasconcelos, F. Jorge Lino, Rui J. Neto, Advanced Materials Forum, 1<sup>st</sup> International Material Symposium, Coimbra, Portugal, Key Engineering Materials, Ed. by T. Vieira, Vol. 230-232, 169-172 (2002).
2. P. Vasconcelos, F. Jorge Lino, Rui J. Neto, Tecnometal 136, 17-21 (2001).
3. F. Jorge Lino, F. Braga, M. Simão, Rui J. Neto, T. P. Duarte, Protoclick – Prototipagem Rápida, Protoclick, Porto, Portugal (2001).
4. C. K. Chua, K. F. Leong, C. S. Lim, Rapid Manufacturing: Principles and Applications, World Scientific Publishing Co. Pte Ltd. (2003).
5. T. Wohlers, Report 2003 – Rapid Prototyping, Tooling & Manufacturing, State of the Industry, Annual Worldwide Progress Report, Wohlers Associates, Colorado (2003).
6. C. K. Chua, K. H. Hong and S. L. Ho, Int. J. Adv. Manuf. Techn. 15, 609-614 (1999).
7. L. J. Grant, Plastic Design Forum, 36-38, October (1994).
8. R. N. Dunlop, First National Conference on Rapid Prototyping and Tooling Research, 249-256 (1995).
9. P. Vasconcelos, F. Jorge Lino, R. J. Neto, Proceedings of 1as Jornadas Politécnicas de Engenharia Mecânica, Leiria, Portugal (2001).

10. P. Vasconcelos, F.J. Lino, R. Neto, P. Henrique, Proceedings of the II International Materials Symposium, Apr. 14-16, Caparica, Portugal, Ed. By R. Martins, E. Fortunato, I. Ferreira and C. Dias, ttp Trans Tech Publications, 635-638 (2004).
11. P. Vasconcelos, F. J. Lino, F. V. Hattum, R. Neto, Proceedings of the II International Materials Symposium, Apr. 14-16, Caparica, Portugal, Ed. By R. Martins, E. Fortunato, I. Ferreira and C. Dias, ttp Trans Tech Publications, 742-745 (2004).
12. P. Vasconcelos, F. J. Lino, R. Neto, RPD 2004 – Rapid Product Development Conference, Marinha Grande, Portugal, October 12-13 (2004).
13. P. Vasconcelos, F. J. Lino, A. M. Baptista, R. Neto, accepted for publication in J. Wear, October (2004).
14. ASM, Properties and Selection: Non Ferrous Alloys and Special-Purpose Materials, ASM Handbook, ASM International, Vol. 2 (1992).
15. G. Henges, W. Michaeli and P. Mohren, How to Make Injection Moulds, Hanser (2000).