

UWB over Fiber

Abdelgader Abdalla¹, Antonio Teixeira², Mário Lima³

a.m.abdalla@av.it.pt¹, teixeira@ua.pt², mlima@ua.pt³

† Instituto de Telecomunicações, Universidade de Aveiro, Portugal

ABSTRACT

The aim of this work is to develop a nonlinear model for Optical millimeter-wave signal generation by up and/or down-conversion system based on simple technologies, which can tend to be low-cost, vital to future real deployment in access networks.

A Mach Zehnder interferometer (MZM) is used to generate high frequency optical OFDM signals by means of its nonlinearity.

The maximization is based on the Taylor series expansion.

INTRODUCTION

- Several optical mm-wave generation approaches were reported recently, such as direct modulation, optical double-frequency heterodyning [1], external optical modulation [2], [3],[4] etc.
- We focus on the simplification of the central office (CO) and of the base station (BS) by optical generation/detection of mm waves and signals.

Simulation set-up

Simulation set-up (Fig. 1),

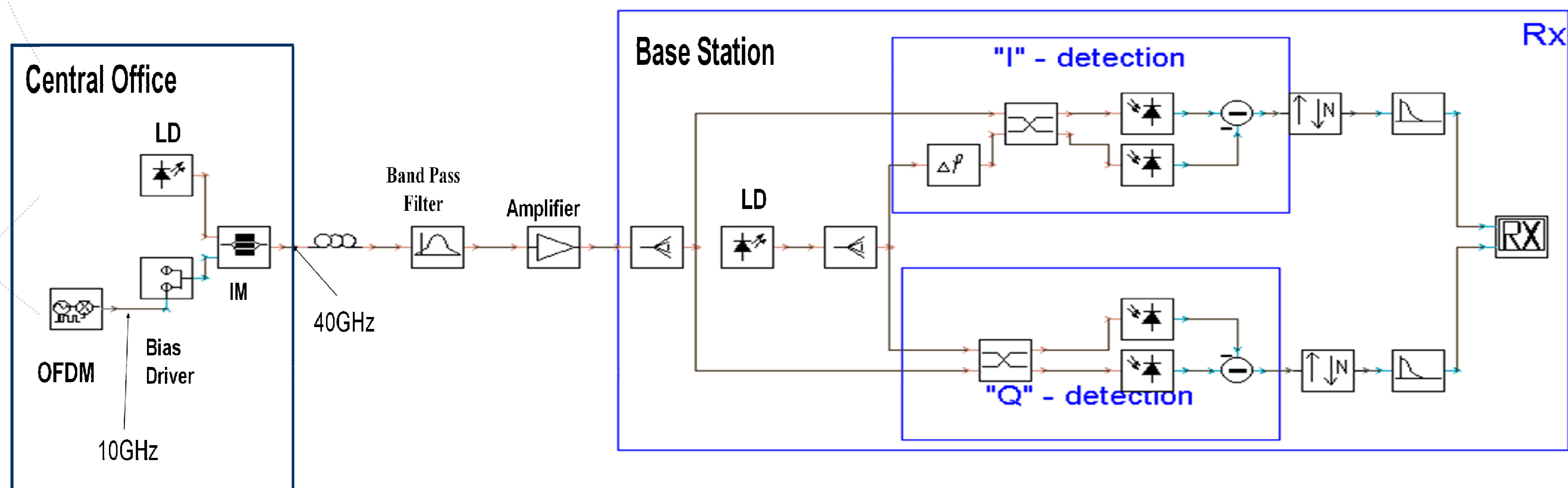
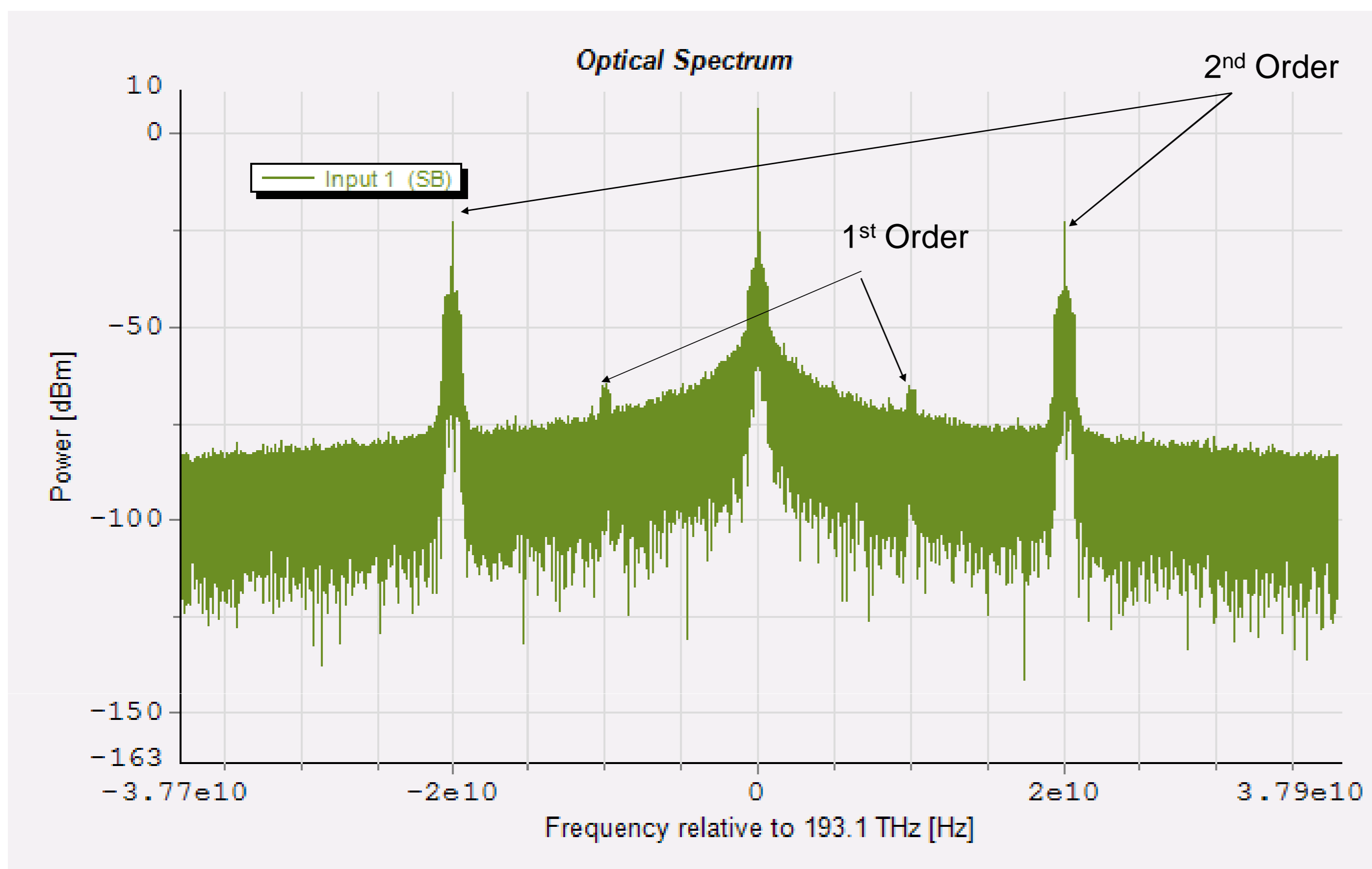

Fig. 1. Double-Sideband Modulation & Coherent Heterodyne Detection Architecture . (LD: laser diode, IM: intensity modulator) Simulation setup .

1st SIMULATION RESULTS



Fig(2) Simulation result of the generation of the optical millimeter-wave (mm-wave) using one MZM intensity modulator (IM) and a 10 GHz local oscillator (LO).

- 1st order is suppressed and 2nd order appears stronger

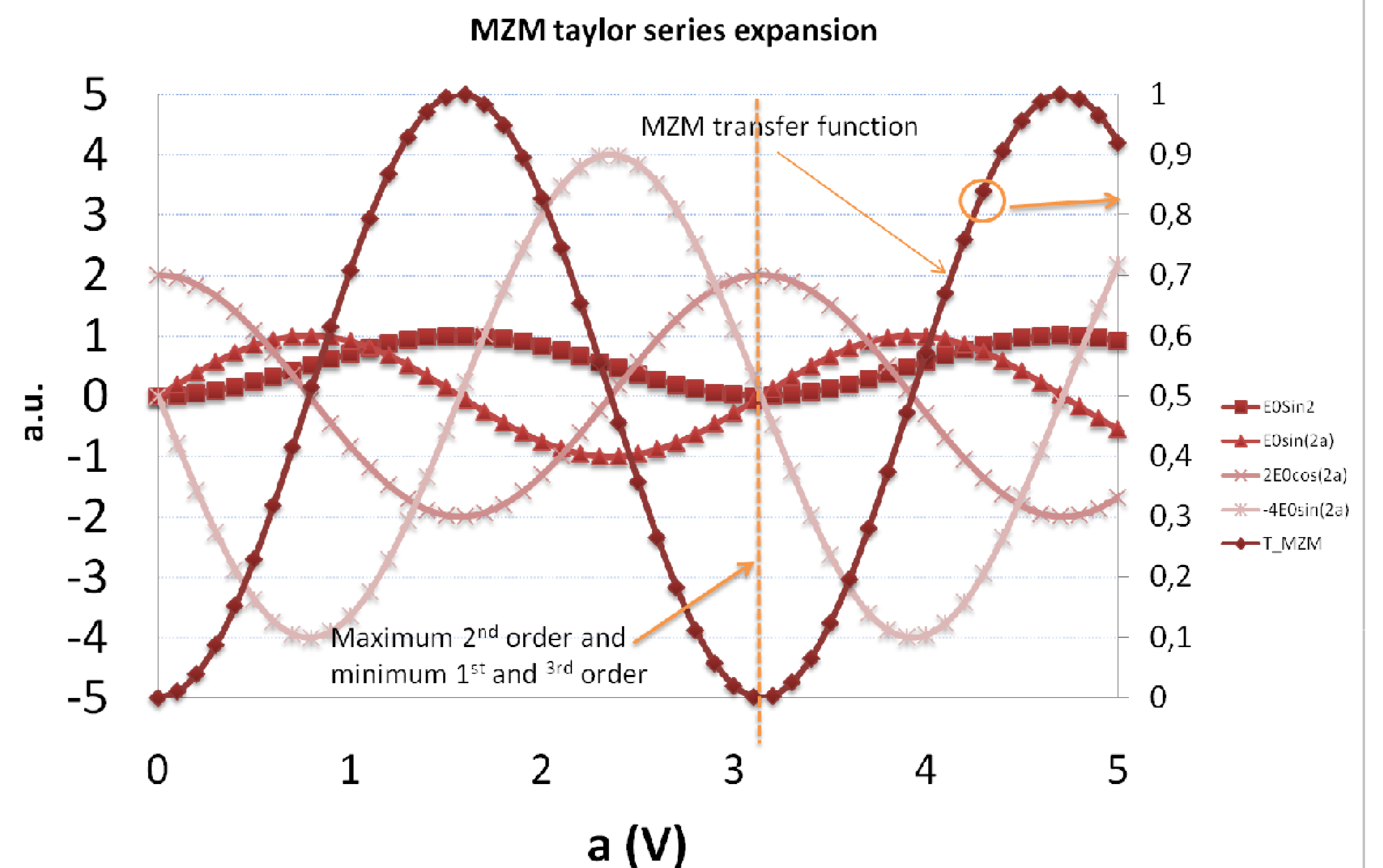

Fig(3) V bias Vs Second Order of Power Series at Different Expansion Point a

- V bias equal to 3.1 V minimizes all other components and maximizes 2nd

The MZM power transfer function can be approximated by

$$f(V_{bias}) = E_0 \sin^2(kV_{bias}) \quad (1)$$

•the laser diode power (E_0) and the bias point (V_{bias}), k is a calibration constant

•The Taylor power series for equation (1) follows (a - the expansion point) :

$$f(V_{bias}) = E_0 \sin^2(a) + E_0 \sin(2a) \frac{V_{bias} - a}{1!} + 2E_0 \cos(2a) \frac{(V_{bias} - a)^2}{2!} - 4E_0 \sin(2a) \frac{(V_{bias} - a)^3}{3!}$$

CONCLUSION

- We confirm that it is possible to generate optical 40GHz millimeter-wave (mm-wave) just by adjusting the bias point and a oscillator of 10GHz.
- The Taylor series is an important tool for that purpose.
- Further research is going on, on enabling Coherent Heterodyne Detection of High-Bit rate OFDM.

REFERENCES

- [1] M.F.Huang, J.Yu,Z.Jia, G.K.Chang, "Simultaneous Generation of Centralized Lightwaves and Double/Single Sideband Optical Millimeter-Wave Requiring Only Low-Frequency Local Oscillator Signals for Radio-Over-Fiber Systems" LIGHTWAVE TECHNOLOGY, VOL. 26, NO. 15, AUGUST 1, 2008
- [2] J. Yu, Z. Jia, T.Wang, and G. K. Chang, "Centralized lightwave radioover-fiber system with photonic frequency quadrupling for high-frequency millimeter-wave generation," IEEE Photon. Technol. Lett., vol.19, no. 19, pp. 1499–1501, Oct. 2007.
- [3] G. Qi, J. Yao, J. Seregelyi, S. Paquet, and C. Belisle, "Generation and distribution of a wideband continuously tunable millimeter-wave signal with an optical external modulation technique," IEEE Trans. Microw.Theory Tech., vol. 53, no. 10, pp. 3090–3097, Oct. 2005.
- [4] Z. Jia, J. Yu, and G. K. Chang, "A full-duplex radio-over-fiber system based on optical carrier suppression and reuse," IEEE Photon. Technol. Lett., vol. 18, no. 16, pp. 1726–1728, Aug. 2006.

Acknowledgment

The authors greatly acknowledge the financial support provided by FCT ROFWDM (PTDC/EEA-TEL/68973/2006) .